

**TITLE: Quick-Lock Piping System – Installation Instructions**

**Purpose:** This document covers the installation instructions for the **Quick-Lock piping system** supplied through Champion.

**Scope:** This document covers the Quick-Lock piping range, specifically sizes **20mm through 63mm** inclusively.

## Instructions:

**Before installation of any Quick-Lock pipe or fittings, the following instructions must be carried out:**



**WARNING !!**

**Failure to follow instructions and warnings could cause system failure, resulting in serious personal injury and/or property damage.**

**Every installation of this product is different and may contain certain unique hazards. It is your responsibility to exercise caution and work safely.**

**Champion cannot guarantee your safety while installing or testing Quick-Lock Piping.**

**If you have questions do not attempt to install or test this product. Contact customer support for more information. 704-947-6966**

The following are the minimal required Personal Protective Equipment: Additional site-specific safety equipment may be required. Always wear safety glasses, gloves, hardhat, foot protection, and hearing protection. Never work alone.



**Important:** This Installation Instruction sheet only applies to tube to tube connections. All other fittings such as (but not limited to): Threaded Connections, Saddle Clamps, Hanging Systems and Quick Connections are not covered in this installation manual. Please call Customer Support for more information or questions (704-947-6966)

## **Fitting size 20mm through 40mm:**

1. **Inspect fittings to insure components are free from damage.**

**Note:** Fitting and tube damage can occur during shipping or rough handling. Special care should be given to protect the end of the tubing as well as the outer edge of the fittings from damage.

## Fitting Components:

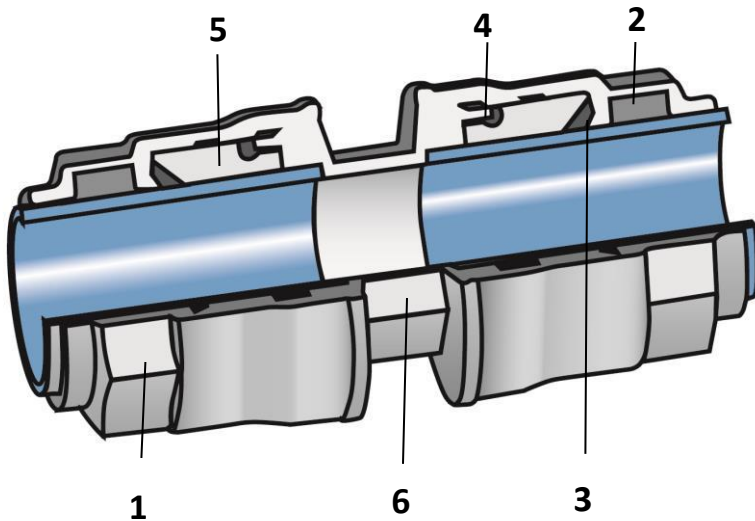

Component part and material

<b>1</b> Nut: Nickel-Plated Brass	<b>4</b> O-Ring Seal: NBR
<b>2</b> Seal: High Nitrile	<b>5</b> Safety Ring: Technopolymeric
<b>3</b> Clamping Washer: Inox AISI 304	<b>6</b> Body: Nickel-Plated Brass

## 2. Debur pipe outer diameter (OD)

- a. Caution: Do not loosen the compression nuts prior to pipe installation. The fitting compression nuts are pre-torqued at the factory.
- b. To install the pipe, push and rotate the pipe into the fitting until fully seated.
- c. Verify the compression nuts are tight.

### Minimum torque:

20mm	=	27 in.lbs.
25mm	=	27 in.lbs.
32mm	=	35 in.lbs.
40mm	=	58 in.lbs.

## Fitting size 50mm and 63mm:

1. Inspect fittings to insure components are free from damage.

**Note:** Fitting and tube damage can occur during shipping or rough handling. Special care should be given to protect the end of the tubing as well as the outer edge of the fittings. (Refer to diagram above)

2. **Deburr pipe outer diameter (OD)**

- a. Loosen the compression nuts prior to pipe installation.
- b. Push and rotate the pipe into the fitting until fully seated.
- c. Tighten the compression nuts to a minimum torque of 55 ft.lbs.

## Pipe Removal:

### **Ensure system is fully depressurized!!!**

Loosen the fitting compression nut 1 to 1.5 turns, push the pipe into the fitting and then pull tubing from fitting.

For further clarification on this requirement please call the manufacturer for assistance – **704-947-6966**

	DESCRIPTION OF CHANGE	DATE	APPROVALS	
			President	QA
0	Initial Release	n/a	PA	DP
1	Layout changes only	1-18-12	PA	ML
2	Addition of safety requirements	6-30-14	PA	TZ
3	Addition of safety requirements	10-22-14	PA	TZ
4	Addition of safety requirements	2-26-15	PA	TZ
5	Logo Revision	10-26-15	ML	TZ